

VTL

TP-6.5 Signature Phono Stage

Owner's Manual

MAKING TUBES USER FRIENDLY

VTL TP-6.5 Signature Phono Stage

Information in this document is subject to change without notice. No part of this document may be reproduced or transmitted in any form or by any means, electronic or mechanical, for any purpose, without the express written permission by VTL.

Version History: 2.0

Version: April, 2009

Part Number: OM-TP6.5

Copyright © 2009 by VTL Amplifiers Inc. All rights reserved.
4774 Murrieta Street, Suite 10
Chino, CA 91710, USA
Phone 909.627.5944 • Fax 909.627.6988
Email: mail@vtl.com • <http://www.vtl.com/>

Table of Contents

CHAPTER 1	1
INTRODUCTION.....	1
Circuit Features:.....	1
<i>Symbol Conventions used in this guide</i>	2
<i>Electrical Safety Notice</i>	2
<i>Water and Moisture</i>	3
<i>Location and Ventilation</i>	3
<i>Warning – To avoid risk of failure due to overheating, do not stack components</i>	3
<i>Servicing</i>	3
<i>Operational Warnings</i>	4
CHAPTER 2	5
GETTING STARTED.....	5
<i>Unpacking the TP-6.5 from its box</i>	5
<i>Quick Start</i>	6
<i>TP-6.5 Front Panel Controls</i>	7
Summary of the Front Panel Functions:.....	8
<i>The TP-6.5's Back Panel</i>	9
Back Panel Connections and controls.....	10
<i>The Remote Control Hand-held Unit</i>	11
Fitting the Batteries to the Remote Control.....	13
<i>Voltage Setting</i>	13
<i>Power Source for the VTL TP-6.5 Preamplifier</i>	13
<i>Connecting the TP-6.5 to your system</i>	14
Connecting to a Turntable.....	14
CHAPTER 3	15
OPERATING THE TP-6.5 PHONO STAGE.....	15
<i>Powering your Phono Stage and the rest of your system on</i>	15
<i>Ground Loop Hum</i>	16
<i>Using the TP-6.5 with the Remote Control</i>	16
<i>Operating Modes and Factory Default Settings</i>	17
<i>Special Programming Functions</i>	18
<i>Powering the system off</i>	19
CHAPTER 4	20
CARE AND MAINTENANCE OF YOUR VTL TP-6.5 PHONO STAGE.....	20
<i>Break In Period</i>	20
<i>Tube Life</i>	20
<i>Changing Tubes</i>	20
<i>Changing the Main Power Supply Protection Fuses</i>	24
<i>Cleaning</i>	25
<i>Troubleshooting</i>	25
CHAPTER 5	28

TP-6.5 SPECIFICATIONS.....	28
CHAPTER 6	29
WARRANTY.....	29
APPENDIX	31
<i>Warranty Registration</i>	<i>31</i>
<i>Service Notes</i>	<i>31</i>

Introduction

Congratulations on your purchase of a VTL Signature Phono Stage: "A new single-chassis phono stage design to challenge all others."

This hand crafted component is designed to deliver superb performance for your listening pleasure for many years to come. In order to get the most benefit from your purchase, we recommend that you take sufficient time to get familiar with the features of this product. Please take a moment to read through this owner's manual, as it contains all of the installation procedures needed to connect your new TP-6.5 to the rest of your audio system, as well as the many functions that the TP-6.5 can perform. After you have finished reading this manual it should be kept in a safe place for future reference.

The new **TP-6.5 Signature Phono Stage** is designed to complement and match the TL-6.5 and TL7.5 Linestage Preamplifiers in sonic performance, user interface and cosmetics. Our goal is to challenge the current state of the art and develop a standalone MC step up to complement the top VTL linestage preamplifiers, the TL7.5 Series II and TL-6.5, and provide a reference phono step up.

The new TP-6.5 will appeal to VTL's core users who have been waiting patiently for a matching phono stage for their VTL linestages. The new phono stage employs hybrid JFET/tube circuitry for quiet operation, multiple low-noise cascaded regulators and shielded power supplies for dynamics, accurate 4-corner passive RIAA equalization and 68dB of gain from the balanced outputs, all in a single chassis unit. All of the required user settings are offered, both via front panel and remote control.

The new design yields a wide and deep soundstage, realistic image proportions, and startling dynamic range and speed, with massive headroom capability and low noise. With the final voicing complete there is even more refinement and nuance, with a delicacy that is especially noticeable in the way the sustain and decay of instruments are captured, and yet at the same time it retains the classic VTL characteristic of solid, controlled bass.

The VTL team is proud that you have selected our Signature phono stage as a new member of your home audio system. This TP-6.5 is designed to give you the convenience and flexibility to manage all cartridges, while at the same time giving you the musical experience that is the most alive and the truest to your source, and we certainly wish you many hours of enjoyment from it.

Circuit Features:

- 2 single ended inputs, with discrete load settings for each input
- Single-ended and Balanced outputs, with 68dB total gain balanced
- Active Hybrid low noise J-FET driving high current 12AU7 mc gain stage for highest resolution of small signal levels
- All high fidelity tubes: 12AU7, 12AX7, 12AT7, all operating in linear range
- Accurate 4-corner passive RIAA filter, with split pole for greater accuracy
- Zero loop feedback

- Gain trims for accurate channel to channel balance
- Signature and Reference-level coupling capacitors
- Shock mounted gain stages for resistance to vibration interference
- Extensive RF filtering on AC path
- Switchable RF filtering on both inputs.
- Low radiation UI core power transformers, with dual mono supplies, and separate logic supply
- Dual mono multiple cascaded precision-regulated and shielded power supplies for low noise, with film bypass for high frequency performance
- Transformer option for MC step up
- Quiet sleep mode on processor when not in use
- Quiet 7-segment LED display on the front panel (for gain and load display)

Symbol Conventions used in this guide

Certain symbols are used in this owner’s manual to draw your attention to important points being discussed. For your own safety and that of your equipment you should note and heed the warnings that follow these symbols.

The “Warning - Pay particular Attention” symbol used is



And the “Warning – Observe These Precautions for Your Safety” is



Electrical Safety Notice

Electrical voltage from power cables can be hazardous. We recommend that the power cord used with this unit be connected to a properly grounded AC outlet. There are hazardous voltages present in the unit, and to prevent electrical shock, do not remove the cover of this preamplifier, and under no circumstances while the unit is powered on.



Warning – Under no circumstances should any attempt be made to circumvent the ground system to the AC line for any reason. Using a ground lifted system can be potentially extremely dangerous, both to persons that might come in contact with the unit, and to the unit itself, and proper RF shielding cannot be attained without a secure ground connection.



Damage to the unit that is the result of improper AC connection and grounding will not be covered under the warranty.

Prior to connecting this preamplifier to any audio or video equipment in your system, make sure this unit’s power (and the rest of the equipment connected to its input and output channels) is turned off. Adding or removing input or output cables to the preamplifier while the system is powered on can cause damage to the preamplifier and possibly also to the rest of the system.



Water and Moisture

The TP-6.5 should be kept away from sources of water or moisture. If liquid enters the unit it must be immediately returned to your dealer for servicing. In this case you should under no circumstances try to power the unit on - there are hazardous voltages present in this unit that can cause serious injury if they come in contact with you.



Location and Ventilation

Warning – To avoid risk of failure due to overheating, do not stack components

The TP-6.5 chassis emits heat and needs proper ventilation to ensure long operational life. Under no circumstances should the TP-6.5 be stacked on top of or below any other unit.



Ensure that the TP-6.5 is installed in a location that is stable and well ventilated. If the preamplifier is placed in a built-in installation, ensure that there is adequate room for air to flow through the ventilation openings. Allow at least 3 - 5 inches clearance on the top and around the sides of each chassis of the preamplifier. The warranty does not cover units that are damaged due to overheating from incorrect installation.



It is also recommended that the TP-6.5 be sited at least 3 feet away from the power amplifier to prevent possible noise introduction into the system.

Tiptoes or other isolation accessories may prove useful in reducing mechanical vibrations or other external vibrations that might affect sonic performance, and we have found that such accessories can offer definite beneficial sonic improvements when used correctly. In all cases this preamplifier should only be installed in a location that is stable, as warranty does not cover damage due to the unit falling.

Do not place the TP-6.5 next to heat sources such as radiators, stoves or other appliances.

Do not place the TP-6.5 where small children might be able to tamper with the equipment. If it is not possible to place the preamplifier out of the reach of small children it is recommended that power cables be removed when the equipment is not in use.

Servicing



Do not attempt to service the TP-6.5 beyond the procedures described in this manual. For all other service and questions, please contact your authorized VTL dealer or the factory.

Operational Warnings



- It is critical for proper sonic performance of this component that it be properly configured for the mode of operation while playing.



- Always make all connections before powering the TP-6.5 on. Connecting or disconnecting the TP-6.5 while powered on can damage the unit, and will not be covered under the warranty. Ensure that no interconnect cables can become loose during use and that there are no intermittent faults or shorts with the cables.



- Do not attempt to disassemble the TP-6.5 chassis or remove any covers from the unit. Always consult with your VTL authorized dealer or the VTL factory before attempting any service work on any VTL unit.



- Do not touch the tubes after the TP-6.5 is turned on. The tubes can get very hot while the TP-6.5 is operating. Turn off the TP-6.5 and allow the tubes to cool down before attempting to work with the tubes.



- Tube components can be heavy and awkward to lift, with the weight unevenly distributed, and you should not attempt to move the unit without help. The TP-6.5 weighs approximately **50 lbs. (22.72 Kg)**.



- Do not exceed fuse ratings or attempt to bypass any fuses, as this can cause an extremely hazardous condition and will void any warranties. Use only the same type and rating of fuses as specified in the owners' manual and marked on the unit.

Getting Started

Unpacking the TP-6.5 from its box

1. The VTL TP-6.5 Preamplifier is shipped in one carton and the unit is wrapped in thick plastic.  The plastic is not strong enough to support the unit, and may tear if you try to lift the unit out of the box with it. Also there are protruding switches and connectors which could break if the unit is not properly handled, and in addition to the awkward, unbalanced heavy load the unit has sharp edges and a cleaning polish on it, which makes it slippery and hard to grasp.
 2. When lifting the unit, be sure to only lift it from the bottom of the unit with both hands. Be careful not to break any switches or connectors or to rest the unit on any other side than the bottom side on the four feet on a stable surface. Setting it on any other side may damage protruding components.
- ➔ SAVE THE CARTON AND ALL PACKAGING FOR ANY FUTURE SHIPMENT OF THE TP-6.5.

After you open the carton you should find the following items inside:

- The TP-6.5
- 1 standard power cord for the electrical system in your country
- The remote control hand-held unit with two AAA batteries
- This Owner's Manual, VTL Quality Assurance and test printout, and a VTL product warranty registration card

Remove each item from its packaging material and check to make sure that no physical damage has occurred during shipment of the unit. There should be no rattles inside either the preamplifier chassis or remote control units. Look through the vent slots and check to see that the tubes appear properly seated in their sockets. Contact your VTL dealer immediately if physical damage is detected.

Quick Start

As the proud owner of this new VTL TP-6.5 Signature Phono Stage, you are probably eager at this moment to connect it into your system and hear what it sounds like. This section is a quick setup-up guide to help you get started in the shortest time possible. Once the TP-6.5 is in your system and operational, please take the time to read the rest of the information in this manual. It will give you the in-depth perspective into all the functions your TP-6.5 is capable of delivering and how to take advantage of the many special programming functions designed to give you the maximum performance and flexibility.

Step 1: Finding a location for the TP-6.5

We recommend that you place the TP-6.5 in a location as close as possible to your turntable and line stage preamplifier. Note that the TP-6.5 should not be stacked on top of anything else. Reserve sufficient space to either put the unit on its own shelf with at least 6 inches of space above it for ventilation.

Step 2: Connect the TP-6.5 to the AC outlet

Make sure that the *Power Rocker* switch on the back of the unit is not turned on. Locate the IEC power cord that came with your TP-6.5, and connect one end of the power cord to the back of the unit and the other side of the power cord to the AC outlet on the wall.

Step 3: Connect the turntable to the TP-6.5

Make sure the turntable is turned off, and connect it to the appropriate input location on the back panel of the TP-6.5. If your turntable has single-ended out, connect the cable from the output of your turntable to either the MC or MM input of your TP-6.5, depending upon your phono cartridge type and output level, matching the left and right channels. Make sure that you are using the appropriate input cables and that all connectors fit snugly.

If your turntable uses balanced or other outputs, then an appropriate cable will be needed, as the TP-6.5 only accepts single ended connection.

Step 4: Connect your TP-6.5 to the Line Preamplifier

Make sure your Line Preamplifier is turned off. If your preamplifier supports balanced input and you have balanced interconnects, connect the TP-6.5's balanced output to the preamplifier's balanced input, with the right output from the TP6.5 Phono Stage going to the right input of the Line Preamplifier and the left output of the Phono Stage to the left input of the Line Preamplifier.

If you are connecting to your line preamplifier using single-ended interconnects, connect the TP-6.5's RCA/single-ended outputs to the preamplifier's single-ended input, making sure that the left channel of the phono stage is connected to the left channel of the preamplifier and vice versa. The single-ended output is located next to the balanced output connector.

Step 5. Turn on the TP-6.5 Preamplifier

Locate the Power Rocker switch at the back of the unit. Turn the switch to the "on" position. You should see three blue "---" displayed in the unit's Numeric Display window.

Locate the red Power button on the front panel of the unit located on the far left side of the TP-6.5. Push the power button to turn on the TP-6.5. You will see the blue Power on LED above the red Power button start to blink and the Numeric Display now displays the 180 to 0 warm-up countdown sequence.

Step 6. Turn on your turntable

Step 7. Turn on your Preamplifier

Step 8. Turn on your Amplifier

Step 9. Wait for the TP-6.5 to finish warmup

After the TP-6.5's warm-up countdown is completed, the Power on LED turns to a steady blue indicating that the unit is now ready to play. Please note that the Numeric Display is now blank and the red Mute LED is flashing. MC is the default selected input and the LED above MC is blue to indicate the default selection of MC.

Step 10. Unmute the TP-6.5 to start playing music

Start playing your music and press the Mute button to release the mute of the TP6.5.

Congratulations! You have just completed the Quick Start section of your TP-6.5 Phono stage manual. Now please read the rest of this manual while relaxing and listening to your favorite music.

TP-6.5 Front Panel Controls

From the front panel of the unit you can access all of the controls and program all the functions of the TP-6.5

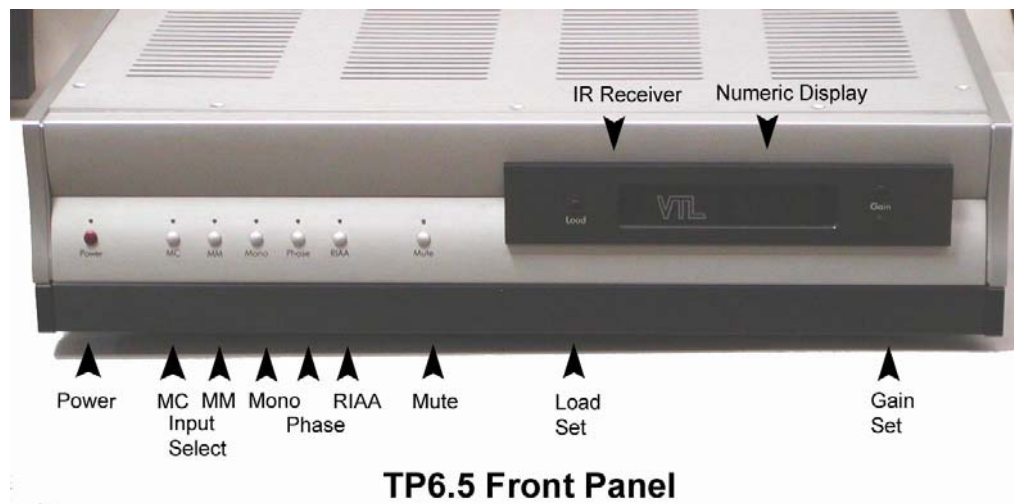

Fig. 1 Front Panel

You can operate the various controls and buttons from the front panel to access the full functionality of this unit, and the operational functionality can also be accessed via the remote control. The indication LEDs show the various operating modes of the unit.

Summary of the Front Panel Functions:

- Power -- On or Off
- Input select – MC or MM
- Mono switch
- Phase flip, absolute, and channel to channel
- RIAA select, for Enhanced RIAA and Rumble cut
- Mute – On or Off
- Load setting:
 - MC: 100, 250, 470, 1K, 2.5K, 4.7K, 47K and User Defined
 - MM – 10K, 22K, 47K and User Defined.
- MC Gain adjust: 5 steps of 6dB: 44dB, 50dB, 56dB, 62dB, 68dB

1. The *Power* button is used to turn the TP-6.5 on and off. If the unit is powered off and in standby mode (as indicated by the “---“ on the Display,) press the button to turn the TP-6.5 ON and press the button again to turn the unit OFF. The *Power* LED will blink blue during warmup, remain on steady blue after power up, and turn off during power off or standby. If the unit is Off and the Display does not indicate “---“, the standby mode, turn on the Power Rocker switch in the back of the unit.
2. The *Input Select* buttons are used to select the input for the TP-6.5. You can choose either of the two inputs, MC or MM, by pressing the appropriate selector button labeled with the selection of your choice.
3. The *Mono* button is used to set the unit into Mono or Stereo mode. This is a toggle control, which changes the state from one to the other each time it is pressed. When the Mono LED is off, the unit is operating in Stereo mode; and when the LED is on, the unit is in Mono mode. Please note that the unit will go into mute temporarily when the Mono button is pressed, with the Mute LED blinking red. When the Mono/Stereo mode change is completed, the unit will unmute itself automatically and the Mute LED will be turned off.
4. The *Phase* button is used to set the TP-6.5 between phase inverting and phase correct mode. This is a toggle control, which changes the state from one to the other each time it is pressed. When the Phase LED is off, the unit is operating in zero phase mode.
5. The *RIAA* button is used to set the unit into Rumble cut or flat mode. This is a toggle control, which changes the state from one to the other each time it is pressed.
6. The *Mute* button is used to set/reset the system in mute and operating modes. This is a toggle control, which changes the state from one to the other each time it is pressed. When the Mute LED is blinking red, the unit is muted.
7. The *Load* button is used to set the cartridge load. The load settings available are 100ohms, 250ohms, 470ohms, 1kohm, 2k5, 4k7, 47k, and User Defined for MC,

and 10k, 22k, 47k and User Defined for MM. (User defined is an open slot for the user or his dealer to solder in the precise resistor load for the cartridge in use.) When you press the Load button, the Display will show the current Load setting. You can press the Load button again to cycle through the various choices for Load. When the correct Load value is selected and displayed, leave the unit as is for about 5 seconds until the Load value on the Display turns off by itself. The newly selected Load value will now take into effect.

8. The *Gain* button is used to increase/decrease the gain by pressing the up and down buttons on the right most side of the Display block. The Gain settings for the MC input are available in 5 x 6dB steps, from 68dB, 62dB, 56dB, 50dB and 44dB. (The gain for MM is set at 40 dB and is not variable.)

Pressing the Gain button once will display the current Gain setting. Press the Gain button again while the Gain value is displayed, the unit will go into Mute to allow you to cycle through the various Load values. Once the correct value is found during this Mute cycle, please wait until the Mute LED goes away and the new Gain value takes into effect.

Warning It is critical for proper sonic performance of this component that it be properly configured for the mode of operation while playing.



9. The *display window* contains the group of three programming buttons, the numeric display, and the infra red remote receiver, which enables the transmission of signal from the remote hand-held unit to be received by the preamplifier. Keep this window clear from any obstruction and out of direct light to allow maximum signal transmission from the remote wand.

The *Numeric* display is used to indicate either the sequential countdown timer during power-up, or the Load or Gain setting of the unit.

The TP-6.5's Back Panel

From the back panel of the chassis you can access the power rocker switch, AC fuse, and the serial number and power consumption of the unit, as well as all of the audio inputs and outputs.



Fig. 2 Rear Panel

Back Panel Connections and controls

- ➔ The *AC Inlet* is used for connecting the TP-6.5 to the AC power from a wall outlet using the power cord.
- ➔ The *Main Fuse Holder* contains the main power fuse. CAUTION: Replace fuses only with fuses of same type and rating. Please contact your authorized VTL dealer to purchase replacement fuses.
- ➔ The *Power Rocker* powers the unit into standby mode. Press up for on and down for off.
- ➔ The *Information label* contains Serial number, AC voltage setting and power consumption information.
- ➔ The *RCA Input Jacks*.
2 pairs of single-ended phono inputs to connect two turntables or arms to the TP-6.5, including low output MC or higher output MM cartridges
- ➔ The *RCA and XLR Output Jacks*.
1 pair single ended and 1 pair balanced Main Outputs
- ➔ The *Ground Binding Post*
Attach the ground cable from your turntable to this binding post to eliminate ground noise



The Remote Control Hand-held Unit



Fig 3. Remote Control Unit

The Remote Control hand held unit supplied with the TP-6.5 allows the user to perform the following functions:

- **Power** -- Power the TP-6.5 on and off. This is a toggle control, which changes the state from one to the other each time it is pressed.
- **Mute** -- Set/reset the system in mute and operating modes by pressing the mute button on the remote control hand-held unit. This is a toggle control, which changes the state from one to the other each time it is pressed.
- **Mono** -- Set the unit into Mono or Stereo mode. This is a toggle control, which changes the state from one to the other each time it is pressed.
- **Phase** -- Set the TP-6.5 between phase inverting and phase correct mode by pressing the phase button. This is a toggle control, which changes the state from one to the other each time it is pressed.
- **MM or MC** -- Select either of the 2 inputs directly

- **Rumble** -- Set the unit into Rumble cut or flat mode. This is a toggle control, which changes the state from one to the other each time it is pressed.
- **Load** -- Set the cartridge load. The load settings available are 100ohms, 250ohms, 470ohms, 1kohm, 2k5, 4k7, 47k, and User Defined for MC, and 10k, 22k, 47k and User Defined for MM. (User defined is an open slot for the user or his dealer to solder in the precise resistor load for the cartridge in use.)
- **Gain Up/Down** -- Increase/decrease the gain by pressing the up and down buttons respectively on the remote control hand-held unit. The Gain settings for the MC input are available in 5 x 6dB steps, from 68dB, 62dB, 56dB, 50dB and 44dB. (The gain for MM is set at 40dB and is not variable.)

When the user first presses any of the buttons on the remote control unit, there may be a short delay before the TP-6.5 completes the processing of the signal sent by the remote, especially if the line of sight to the unit is not clear, or if there is any sort of light interference with the infra red signal. The TP-6.5 will not respond to pressing two buttons at one time, and will only accept the first signal received.

In addition, the remote wand can be used to program another universal remote that can be used in place of or in addition to the supplied remote wand.

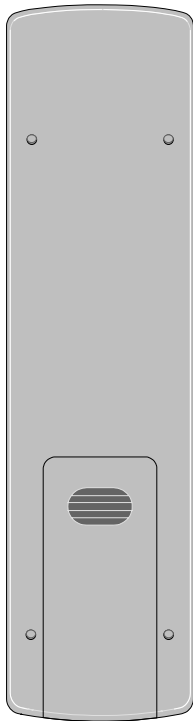

Fig 4. Remote Control Unit Back View

Fitting the Batteries to the Remote Control

1. The back cover of the remote control is a sliding cover that is removable by pressing down on the arrow and sliding the cover off in the direction of the arrow to reveal the battery compartment. Remove the cover and put it aside for re-installation later.
2. Locate the battery holder and insert the two AAA batteries (supplied) in the marked positions, + to + and - to -.
3. Being careful not to damage the cover or the remote shell, replace the back cover and slide it back into position with a snap.

After powering up the TP-6.5, test the remote control functions and ensure that all the functions are working correctly. If the functions are not working then check that the batteries are in the correct mounting positions and that they are not stale. If you still encounter problems then you should call the VTL factory or your VTL dealer.

Voltage Setting

Your VTL TP-6.5 phono stage has already been set to the correct voltage for your country where you made your purchase, and the voltage setting is marked on the Serial Number Badge located on the back panel of your TP-6.5.



→Caution: Check to make sure that the voltage setting on your TP-6.5 is correct for your local voltage rating before plugging in and turning on your TP-6.5.

Power Source for the VTL TP-6.5 Preamplifier

Your TP-6.5 Preamplifier is a high-performance component, capable of extremely high resolution and sonic performance. To assure best conditions for optimal results, plug the unit directly into a wall AC outlet. Do not plug your TP-6.5 into a light extension cord or into the back of another component, as this will starve the TP-6.5 of current and significantly impact the performance of your system.

See the chapter on Specifications for the power consumption requirements of your TP-6.5.

Using the supplied power cable, connect the Phono Stage to the AC line. For electrical safety, ensure that the AC connector fits securely both to the AC line and to the Phono Stage, as a loose connection could cause intermittent operation and may damage the unit.



Warning: Under no circumstances should any attempt be made to circumvent the ground system to the AC line for any reason. Using a ground lifted system can be potentially extremely dangerous, both to persons that might come in contact with the unit, and to the unit itself, and proper RF shielding cannot be attained without a secure ground connection.

Damage to the unit that is the result of improper AC connection or grounding will not be covered under the warranty.

Connecting the TP-6.5 to your system

Connecting to a Turntable

If a direction indicator is printed on the cable make sure that the cable is connected to the source and the Phono Stage in the appropriate direction (arrows flowing in the direction the signal will travel, i.e. from the source to the phono stage.) It is also important that the left and right channels from the source components are connected to the corresponding left and right channels of the Phono Stage.

Connect the TP-6.5 Phono stage to your line preamplifier. Connect the output from the TP-6.5 phono stage to the Phono/Aux 1 input channel of the line preamplifier.

The interconnect cable between the preamplifier and the phono stage links the left and right input channels of the line preamplifier to the left and right outputs of the phono stage.

If a direction indicator is printed on the cable make sure that the cable is connected to the phono stage and the preamplifier in the appropriate direction (arrows flowing in the direction the signal will travel, i.e. from the phono stage to the preamplifier.) It is also important that the left and right channels from the phono stage are connected to the corresponding left and right channels of the preamplifier.

The low output impedance of the phono stage is easily capable of supporting long interconnects up to 10 feet or longer, and can also easily drive any preamplifier or cable load.

There are one set of RCA output connectors and one set of balanced output connectors available from the phono stage, and all are operational at the same time. You can connect your preamplifier to the phono stage using either balanced cables or RCA cables.

Before making any connection to the TP6.5 Phono Stage make sure that the line preamplifier is completely powered down. Any connection while a phono stage is powered up can result in damage to the preamplifier and to rest of the system, and/or a loud hum from the loudspeakers

Operating the TP-6.5 Phono Stage

Powering your Phono Stage and the rest of your system on

After you have properly connected all your source and amplifier components to the preamplifier you are ready to power your system on.

1. If you haven't already done so, ensure that all of the tubes inside the TP-6.5 are properly seated all the way into their sockets before powering the unit from the AC source. Look through the cooling slots on top of the audio chassis in the left half of the circuit board, as you face the unit. If the tubes are not fully seated into their sockets, then disconnect the unit from the AC, and from the rest of the system. Locate the section on Tube Replacement in Chapter 4 of this manual and follow the instructions to remove the cover and reseal the tubes.
2. If the tubes are fully seated then power on the source component(s) you intend to use for your listening session.
3. Make sure that the AC power cord is connected from the TP6.5 to your AC supply.
4. Check the Power On rocker switch on the back of the unit (refer to photo of the back panel in Chapter 2) and turn the rocker switch to the On position. The Display window on the front panel should now indicate that the unit is in standby mode with a "---" display.
5. From the Phono Stage's front panel Power On switch turn on the TP-6.5. When you first power-on your TP-6.5 it goes through a warm-up stage that takes approximately 180 seconds, with countdown status displayed on the front panel numeric display window. During this warm-up period the TP-6.5 is muted. After the warm-up stage is completed, the TP-6.5 automatically goes into the muted mode. The power LED on the unit turns into a steady blue light, indicating that the TP-6.5 is ready for use.

Check to make sure that the unit's status display indicates warm up mode, as indicated by the blinking power LED and a countdown timer display counting from 180 (seconds), decrementing in 1 second steps.

6. Once the TP-6.5 completes its warm up cycle the Power LED will stop blinking to indicate that it has changed from the warm up state into the ready to operate state.

In case the status display does not behave as described check to make sure that the power cable is securely connected to the AC Power connector on the back panel of the unit, and the power cable is securely plugged into the AC supply, with the AC ground securely connected to the ground of the AC supply.

Contact your VTL dealer if the unit still will not power up after these checks have been performed.

A slight clicking noise may be heard through the speakers as the gain changes are made. This clicking sound is normal and has no effect on sonic performance, nor will it cause any damage to your system.

9. The LEDs on the unit's front panel indicate the operating mode of the TP-6.5. For more details on the different operating modes indicated by the LEDs, please refer to the section below on "Operating modes and LED Indications":

Ground Loop Hum

If you get a ground loop hum from your stereo system after installation and power up you should immediately turn off the TP-6.5 and consult your VTL dealer or the VTL factory.



Caution: Under no circumstances should you attempt to lift or defeat any grounds on electrical equipment plugged into the AC, as these grounds are installed for your and the equipment's safety, and an ungrounded component can present an extremely hazardous condition and is illegal under most electrical safety codes. For your own safety please refer all questions of this nature to a properly trained service technician

Using the TP-6.5 with the Remote Control

1. Your TP6.5 remote control hand-held system should come with two AAA batteries installed already. To check that the batteries are installed, open the back of the remote control by gently pressing down on the cover and sliding the back cover off the remote unit. Locate the battery holder and check that the two AAA batteries are installed in the correct directions as marked in the battery holder, with plus on each battery corresponding with the plus sign in the holder. Replace the back cover of the remote.
2. The system can be powered on and off with the power button on the remote control. If the unit is powered off from the remote control, there is a 5 second waiting period during which you can power on the unit using the remote and restore it into power on state immediately without going through the 180 sec. countdown cycle. This special function can only be activated when both the power off and power on functions are initiated from the remote control hand held unit.
3. Use the remote control wand's source buttons to select the desired source.

4. If the system is in mute, (i.e. the Mute LED on the preamplifier's front panel is flashing), press the mute button on the remote control to take the system out of mute mode and put it into operate mode.

5. Use the phase button on the remote unit to toggle the phase status of the system. If the system is in phase correct mode, press the Phase button once to put it into phase inverted mode. The Phase LED will turn from off to red when the system is changed to phase invert.

Operating Modes and Factory Default Settings

Powering the TP-6.5 off from the front panel or remote wand will save all of the existing settings to memory for use at a later power up. Loss of power before the settings are saved will cause the settings to be lost from memory, and the unit will have to be programmed again and the settings saved by powering down from the front panel or remote power buttons. Powering down from the rear rocker switch has the same effect as loss of power, and does not save settings to memory.

Function	Default Mode	Indication
Suppress timer countdown	Not set	Timer decrements
Inputs MC or MM (Defaults to input MC selected)	MC	Selected input LED color is blue
Gain setting	68dB	68.0 on numeric display when Gain is pressed
Mute	Always Muted on Power up	Mute LED flashing
Phase	Phase correct	Phase LED off
RIAA	Off	RIAA disabled
Load	47K for both MM and MC	47K on the display when Load is pressed
Mono	Off	Stereo
Programming Lock Out	Not set	None

Special Programming Functions

Please use the front panel buttons to enable and disable the following special programming functions.

Function	Programming Sequence
Disable Input	Select the input to be disabled and hold down that input button until its LED is turned off (about 5 seconds.) This input is now disabled.
Re-enable Input	Hold down the disabled input button until the LED disappears on the active Input and the LED for the disabled Input is now turned on. This input is now re-enabled and selected. Note that the user should not continue to hold onto this input button at this point otherwise the other input will be disabled.
Load and Gain Lockout	Press power down button on the front panel and press the mute button within 3 seconds. "LOC" will appear briefly on display to indicate that the Load and Gain values are now locked and cannot be changed. The next time the unit is turned on, the Load and Gain buttons will only indicate the current stored values and the user cannot change these two functions to other values.
Load and Gain Unlock	To undo the Load and Gain Lockout function, power off the unit and press the Mute button. Turn on the unit within 3 seconds of the power off action. "Unl" will be displayed briefly on the Display window. Now you can change the Load and Gain functions the next time the unit is turned on.
Phase Setting – both channels are in the same phase	Press Phase button once, the Phase LED is turned on steady and red and both channels are in inverted phase. Press the Phase button again to restore both channels to positive phase. The Phase LED should now be turned off.
Phase Setting – one channel is out of phase with respect to the other channel	With the Phase LED off, hold down the Phase button until the LED starts blinking in red. Now one channel is out of phase with respect to the other. Hold the Phase button again until the LED is turned off. Now both channels are back to positive phase.

Turn On Rumble Filter	With the RIAA LED off, press the RIAA button once. The LED turns green indicating that the Rumble Filter function is turned on.
Turn off Rumble Filter	With the RIAA LED on and green, press the RIAA button once and the LED is turned off to indicate that the Rumble Filter function is disabled.
Turn on Enhanced RIAA	With the RIAA LED off, hold the RIAA button until the LED turns blue (about 5 seconds) to turn on Enhanced RIAA compensation.
Turn off Enhanced RIAA	With the RIAA LED on and blue, hold the RIAA button until the LED is turned off. Now Enhanced RIAA compensation function is disabled.
Turn on both Enhanced RIAA and Rumble Filter	With the RIAA LED in green indicating Rumble Filter is on, hold down the RIAA button for about 5 seconds. The RIAA LED turns to red indicating that both Enhanced RIAA and Rumble Filter are now on.
Turn off both Enhanced RIAA and Rumble Filter	<p>With the RIAA LED in red, hold the RIAA button for about 5 seconds, the RIAA LED will become green to indicate that Rumble Filter is on. Press the RIAA button again and the LED will be turned off indicating that both Rumble Filter and Enhanced RIAA are now disabled.</p> <p>When the RIAA LED is in red, press the RIAA button once will turn the LED to blue indicating that Enhanced RIAA is on but Rumble filter is off. Hold the RIAA button now for 5 seconds until the LED is turned off. Now both Enhanced RIAA and Rumble Filter are turned off.</p>

Powering the system off

You may keep your VTL phono stage and your source components on during the day if you prefer to keep them warm. If you prefer to keep all your equipment off when not in use then it is best to follow the correct turn off sequence to avoid power off thumps through the system.

1. When you are done listening to your system always turn your power amplifier(s) off first, if not using the trigger function on the line preamplifier.
2. Allow a short time (15 - 20 seconds) for the amplifier(s) to power down before you turn the TP-6.5 off. If the trigger function is being used, powering the preamplifier off will automatically turn off the power amplifier(s).
3. Turn the source components off, if you prefer to keep these off when not in use.

Care and Maintenance of your VTL TP-6.5 Phono Stage

Break In Period

Your VTL TP-6.5 is a hybrid product designed to give you the continued optimum performance over an extremely long time period. Initially the tubes and circuits will require a burn-in period to reach maximum performance. During the first 100 hours of usage the TP-6.5 will undergo several improvements in sound. To break in the TP-6.5 you can use a compensated low signal level connected to it and playing. It is not necessary to have the power amplifier on during this break in period, as the TP-6.5 will still pass the signal.

Tube Life

Your VTL preamplifier has been designed to ensure long tube life. Tube replacement need not be considered until after approximately 1000 hours of use (roughly 2 years depending on your listening requirements.) As the tubes age beyond their peak performance there will be a general softening of the sound.

We recommend a complete replacement of all the tubes in your Phono Stage at that time, which will restore it to a “like new” sound quality. The tubes used in your TP-6.5 Signature Phono stage are specially matched and tested for this unit. Please contact your VTL dealer or VTL factory service department to order the matched tubes for the Phono Stage.

Note: use only tube types and tube brands that are recommended by VTL. VTL specified replacement tubes are available from your authorized VTL dealer or the VTL factory service department. Any damage incurred to units which use non-VTL approved tubes will not be covered under the warranty.

Changing Tubes

Do not attempt to change tubes yourself. Contact your authorized VTL dealer or the VTL factory service department and have the service performed by a trained technician. You will need to take the unit and this procedure to your dealer for them to perform this procedure properly.

Notes to the Service technician:

Re-tubing the VTL TP-6.5 requires removal of some or all of the covers, which can expose potentially lethal voltages. Be sure to only touch the tubes themselves, and do not allow any part of your body or hanging jewelry to come into contact with any part of the circuit inside the unit.

Before working on the inside of either of the phono stage chassis it is strongly recommended that the power supplies be properly discharged, as they can hold a charge for a long time after power down, and can cause damage to the circuit if discharged improperly.



When you look down from the top, you will see a printed circuit board mounted inside the phono stage. **WARNING: DO NOT TOUCH ANYTHING INSIDE THE PREAMPLIFIER WITH YOUR FINGERS OR WITH ANY METALLIC OBJECT, UNTIL AFTER THE UNIT HAS BEEN SAFELY DISCHARGED.**



VTL preamplifiers can store energy in the power supplies long after they have been turned off, and incorrectly discharging the unit can damage the circuits, which will NOT be covered under the warranty. Be sure to understand these constraints before going any further. If at this stage you feel that you would rather not attempt this procedure yourself you should send the unit to VTL to have the work done.

Locate the tubes, which are plugged into sockets on the PC board. There are a total of eight tubes, two 12AU7 tubes, two 12AX7 tubes and 4 12AT7 tubes. Looking from above and with the top cover removed, the tubes are located as follows:

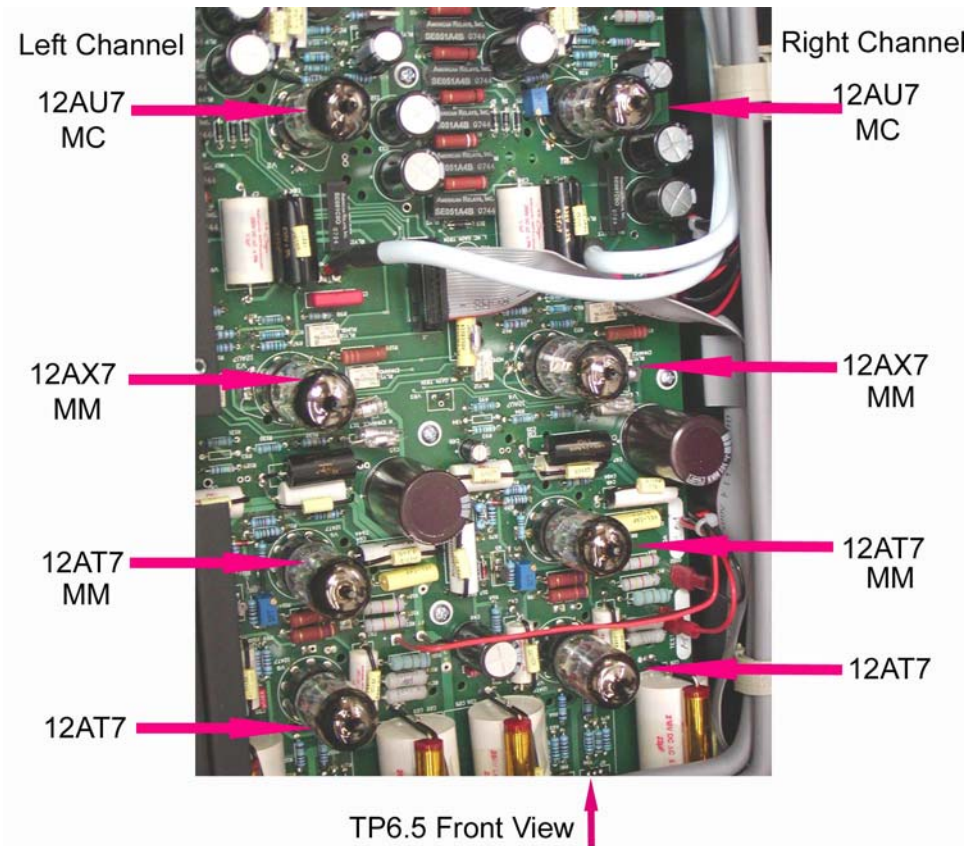

1. Diagnose the tubes: If you are not undergoing a complete re-tube for the entire TP-6.5, then you must first decide how many tubes and which tubes should be changed. Checking the tubes to determine whether they are within the acceptable performance is strongly recommended – contact the factory for ideal operating ranges.
2. Power off the TP-6.5: To change tubes in this TP-6.5 you should first power the unit down from the front panel as well as the rocker switch in the back, unplug the unit from the wall outlet and disconnect the TP-6.5 from the rest of the system. Let the TP-6.5 stay powered off for at least 15 minutes before working with it. Make sure the tubes are cool before you touch them.



Using a Philips #2 point screwdriver for the top screws and a 7/64 hex driver for the side panels, remove the protective cover from the chassis by removing the hex screws from the left and right top side panels and the Philips flat head screws from the top cover of the TP-6.5. Carefully remove the sides, cover and the screws and store them in a safe place.

3. Removing Tubes: Locate the tube you need to remove and hold onto the upper portion of the tube towards its tip. Being careful not to bend the tube pins, gently and in small amounts rotate and rock the tube with your

fingers to loosen it from its socket until its pins are completely disengaged from the socket. Take the tube out of the unit.

1. Plugging in a new tube: Hold onto the upper portion of the tube towards its tip. Lower the tube onto the socket, making sure that the pins from the tube match the holes in the socket. There are either two pins on the tube which are spaced at a wider distance from each other than the rest of the pins. Make sure that these locators go into the side of the socket that matches. Press the tube firmly into its socket, using a gentle force and a slight “rocking” motion. When the tube is properly and completely inserted into the socket it should be firmly seated and does not give in to any movement at all when you try to rock it gently. If the socket appears loose and not making contact with any or all of the tube pins, the socket should be re-tensioned.

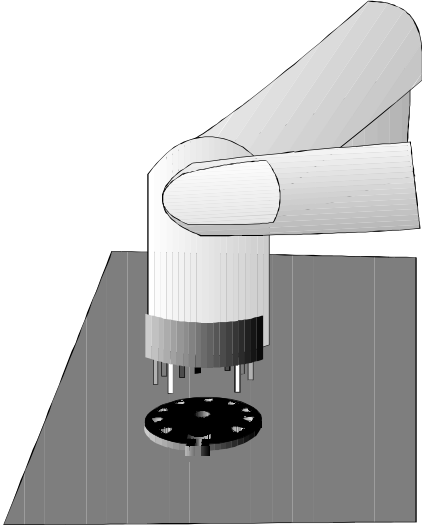

2. Replacing the protective cover: Lower the TP-6.5's cover chassis slowly back onto the opened TP-6.5 box, making sure that the cover is put on in the correct front and back position. Note that the slots on the top cover should match with the slots on the transformer box inside the unit. You should be able to see the parts inside the transformer box through the TP6.5's top cover when it is properly installed. If the parts are not visible through the slots, turn the cover around and install it in the other direction. Locate the screws that were removed from the cover and put them back in the correct holes. Replace the top left and right side panels and tighten all screws to make sure that the cover is securely fastened to the unit.



3. Note that the slots on the top cover should match the slots on the transformer box inside the TP6.5. You should be able to see the parts inside the transformer box through the TP6.5's top cover when it is properly installed. If the parts are not visible through the slots, turn the cover around and install it in the other direction. See photo below for a properly installed top cover.

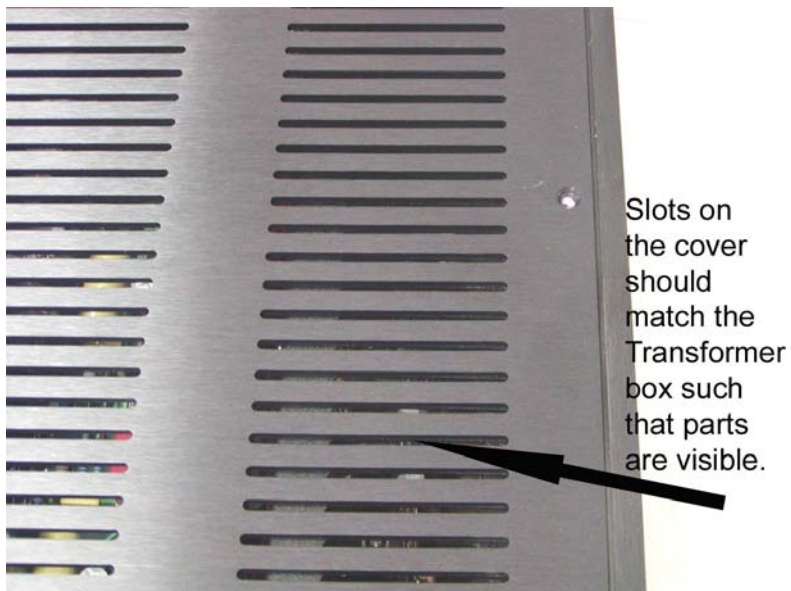

Slots on the cover should match the Transformer box such that parts are visible.

TP6.5 Phono Preamp Top cover correct direction with parts showing.

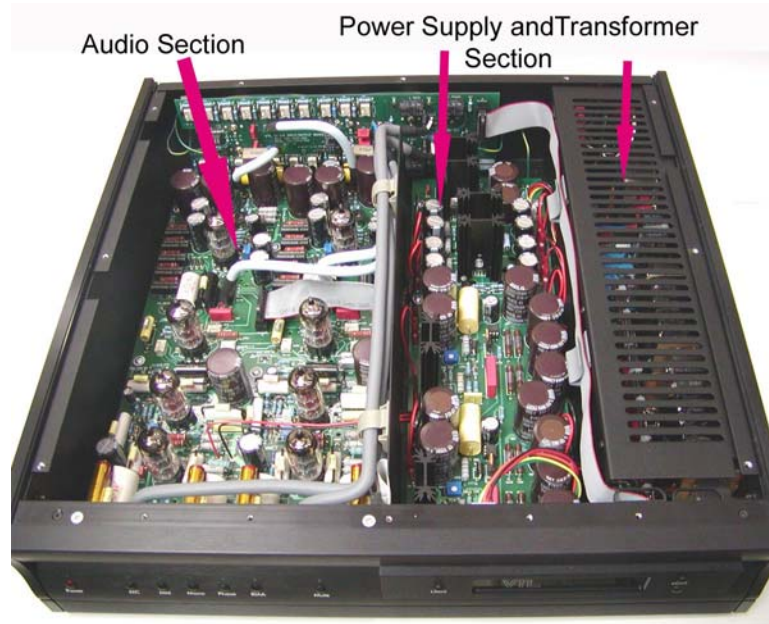

TP6.5 Internal View

Changing the Main Power Supply Protection Fuses

The Main fuse is housed in a fuse holder located on the back panel of the TP-6.5, and is rated at 2A Slo Blo (100/120Volt AC) or 1A Slo Blo (220/240 Volt AC) ceramic.

To change the AC fuse first ensure the unit is powered off, and disconnect the AC power cord from the unit. Move the TP-6.5 so that you can work with the panel in the back of the chassis.

The type of fitting used for the fuses is called a bayonet fit, which describes the action needed to remove the fuse cap. Locate the Main fuse holder, and loosen it by inserting a flat head screwdriver into the slot and turning the screw head approximately one quarter of a turn in a counter-clockwise direction while pressing inwards. The fuse cap should spring out from its housing with the fuse held inside the cap. Take the fuse out and replace it with a new one, and insert the fuse cap back into the holder, pushing it downward while turning it in the clockwise direction to lock it in place. Use the same procedure to replace the output stage protection fuses.



WARNING: For continued protection against fire hazard only replace the fuse with the same type and rating as was originally specified for the TP-6.5. If you have problems locating the correct fuse contact your VTL dealer or the VTL factory service department.



WARNING: Before powering on the TP-6.5 after a fuse change it is extremely important to find the problem that caused the fuse to blow in the first place. Consult your dealer or the VTL factory for service.

Cleaning

Your VTL phono stage should be dusted occasionally with a damp non-abrasive cloth. Do not use any solvents for cleaning the front panel, as this can damage the lettering and the finish. It is recommended that you use a contact cleaner such as Pro-Gold on the input and output connectors regularly to ensure optimum sound and proper signal conducting capability.

Troubleshooting

1. When I power on the unit from the rear rocker switch, nothing happens. What should I do?

Check to make sure that the power cord is properly connected to the unit and the AC outlet. If there is no problem with the power source, check the fuse in the back panel of the unit. If the fuse is blown, change the fuse, and turn the power on the unit again. If the problem still persists, contact your authorized VTL dealer immediately.

2. When I play my record the volume level seems to be too loud. What is the problem and what can be done about it?

Some phono cartridges have higher outputs than others, and the user can lower the gain setting to set the gain as needed.

3. Using the remote control from another stereo component in my system affects the control of my VTL phono stage. Why is this happening and what should I do?

Your VTL phono stage is equipped with a remote control receiver unit that decodes signals coming from a proprietary micro controller code set that is based on the NEC code set. If you own another stereo component that comes with a remote control unit using the same micro controller code set, the VTL unit could pick up signals transmitted from this component as well. If your other remote unit also adopts the same standard, then there is a chance that the signals from both remotes may be interpreted as the same. If the functions with the same command are different for both units then one or other of the remote controls will have to be re-programmed. Contact your VTL Dealer or the Factory for a solution to this problem. *Note that in either case there is no damage being done to your VTL phono stage while it is being used in these states, and you can continue to safely use the phono stage until a solution is reached.*

Please contact the VTL factory service department to report this problem, as we would like to be made aware of which models of stereo equipment could cause this problem.

4. I am getting a noise and hum coming from my system when I turn the amplifiers on. What can I do to eliminate the noise?

It is recommended that you connect as many components as possible to a good clean AC ground in your system, and for quietest operation it is recommended that all components be plugged into the same ground potential (or same AC outlet, if this is not possible.) If however there are too many paths to ground then a ground loop hum can result and you should either contact your dealer or the VTL factory to try to resolve this problem.

5. I am getting a noise and hum coming from my video source. What can I do to eliminate the noise?

The noise may be coming in from your video cable system. First disconnect the VCR from the system to see if this will solve the problem. If it does then you will need to try to lift the ground from the cable TV wire by means of a cable ground lifting transformer available from most electronics stores. If the problem still persists contact your VTL authorized dealer or the VTL factory service department.

6. I am getting a ringing noise from the preamplifier when I touch or bump it. What should I do?

One or more of the tubes in the preamplifier may be microphonic and the source of the problem. Follow the procedures listed in this manual to remove the tubes and change them for new ones.

7. My remote control hand held unit for the preamplifier is not working. What should I do?

Look at the back of the remote control unit. Open the back cover and locate the two batteries inside the remote unit, and take the old batteries out and replace them with new AAA batteries. Put the back cover on and test the remote unit to see if it is working properly.

If the remote control unit is still not functioning properly, contact your VTL authorized dealer or the VTL factory service department.

TP-6.5 Specifications

Vacuum Tube Complement	2 x 12AU7 MC; 2 x 12AX7, 2 x 12AT7MM; 2 x 12AT7
Inputs	2 pairs single-ended/RCA
Outputs	1 pair balanced out XLR out 1 pair single-ended RCA out
Remote Control Functions	Power MC/MM Source Select Gain up/down Mute Rumble Load Mono Phase
Maximum Gain	MC: 62dB single ended, 68dB balanced MM: 35 dB single ended, 40 dB balanced
Output Impedance	150 Ohms
Input Impedance (Cartridge Load)	Selectable MC: 100, 250, 470, 1K, 2.5K, 4.7K, 47K Ohms, User Defined Selectable MM: 10K, 22K, 47K, User Defined
Frequency response + 0 - 1 dB	1 Hz - 100KHz
Maximum Output Voltage < 1% THD	10 <u>VRMS@1KHz</u> (10K ohm load)
Channel Separation	> 70 dB @ 1KHz (>65 dB @ 20kHz)
Power Consumption	80 Watts
Weight	50 lbs (22.72 Kg) Fully packed in one box

Warranty

Warranty registration for VTL products is valid in the USA only. International VTL customers should consult the local VTL importer regarding product registration and warranty procedures.

VTL amplifiers and preamplifiers are covered by a limited warranty against defects in materials and workmanship for a period of 90 days from date of purchase by the original purchaser only, solely when purchased from an authorized VTL dealer. The warranty period begins on date of first sale to the end user, or one year after shipment from the VTL factory, whichever is the earlier. A further optional limited non-transferable five-year warranty is available to the original purchaser only upon proper registration of ownership within 30 days of date of first purchase.

In order to ensure the highest level of customer satisfaction, "new" VTL products may only be purchased over-the-counter or delivered and installed by an Authorized VTL Dealer. VTL products that are purchased over the Internet, by phone or mail order are presumed to be "used" and do not qualify for any VTL Warranty.

Proper registration is made by filling out and returning to the factory the original warranty card packed with the unit, along with a copy of the original sales receipt as proof of the original date of purchase, within 30 days of purchase.

The warranty is provided by the dealer where the unit was purchased, and by VTL Amplifiers Inc. Under the terms of the warranty defective parts will be repaired or replaced without charge, excepting the cost of tubes. A six-month warranty on tubes is available with the correct recording of the serial number of the VTL preamplifier on the warranty registration card and mailing it with the purchase receipt to VTL.

If a VTL product fails to perform properly under the above warranty then the purchaser's sole remedy shall be to return the product to the authorized VTL dealer or to VTL Amplifiers Inc, where the defect will be repaired without charge for parts and labor. The product will then be returned via prepaid, insured freight, method and carrier to be determined solely by VTL Amplifiers Inc. All returns to the factory must be in the original packing and accompanied by a Return Authorization, (new packing will be supplied for a nominal charge if needed), accompanied by a written description of the defect. This must be shipped to VTL Amplifiers Inc via insured freight at the customer's own expense. Charges for unauthorized service and transportation costs are not reimbursable under this warranty, and all warranties, express or implied, become null and void where the product has been damaged by misuse, accident, neglect, modification, tampering or unauthorized alteration by anyone other than VTL Amplifiers Inc. VTL does not warrant, in any way, products that are purchased from anyone who is not an Authorized Dealer or that have had their serial number altered or defaced.

This warranty applies only to units used in residential non-commercial use. The warrantor assumes no liability for property damage or any other incidental or consequential damage whatsoever which may result from failure of this product. Any and all warranties of merchantability and fitness implied by law are limited to the duration of the expressed warranty. All warranties apply only to VTL products purchased and used in the USA, and are only applicable within the USA. Products purchased outside the USA may not be registered for warranty with the factory in the USA, but may only be registered with the VTL distributor in the country of purchase. In the case of returns from outside the USA, the owner of the product returned is responsible for all shipping charges, and VTL will accept no shipping or customs duty charges for goods returned to the USA, nor any shipping or customs duty charges for the return of the product to the owner.

Some states do not allow limitations on how long an implied warranty lasts, so the above limitations may not apply to you. Some states do not allow the exclusion or limitation of incidental or consequential damages, so the above exclusion may not apply to you. This warranty gives you specific legal rights and you may also have other rights that vary from state to state.

Warranty Registration

Warranty registration for VTL products is valid in the USA only. International VTL customers should consult their local VTL dealer regarding product registration and warranty procedures.

To obtain valid US warranty service, please fill out the enclosed VTL Warranty Registration card and mail it to the following address with a **copy of your original bill of sale** within the first thirty days of purchase:

VTL Warranty Registration
4774 Murrieta Street, Suite 10
Chino, CA 91710
USA

To help you keep a record of the serial number and purchase information, please enter the following information into this manual.

Product Model Number: _____

Serial Number: _____

Purchase Date: _____

Authorized Dealer: _____

Service Notes

Date	Service	Initials
_____	_____	_____
_____	_____	_____
_____	_____	_____
_____	_____	_____
_____	_____	_____
_____	_____	_____